

Installation Procedure:

1. Remove existing OEM stainless steel sunvisor and set aside fasteners.
2. Remove OEM visor brackets by drilling through huck bolts. 1st use 1/8" drill bit, then follow with 1/4" drill bit
3. In the interior, remove both storage shelf inserts located on the upper console (4 screws in each)
4. Clean back side of sunvisor with alcohol as indicated in 2 sided tape instructions
5. Assemble center brackets and visor halves as shown in Figure A

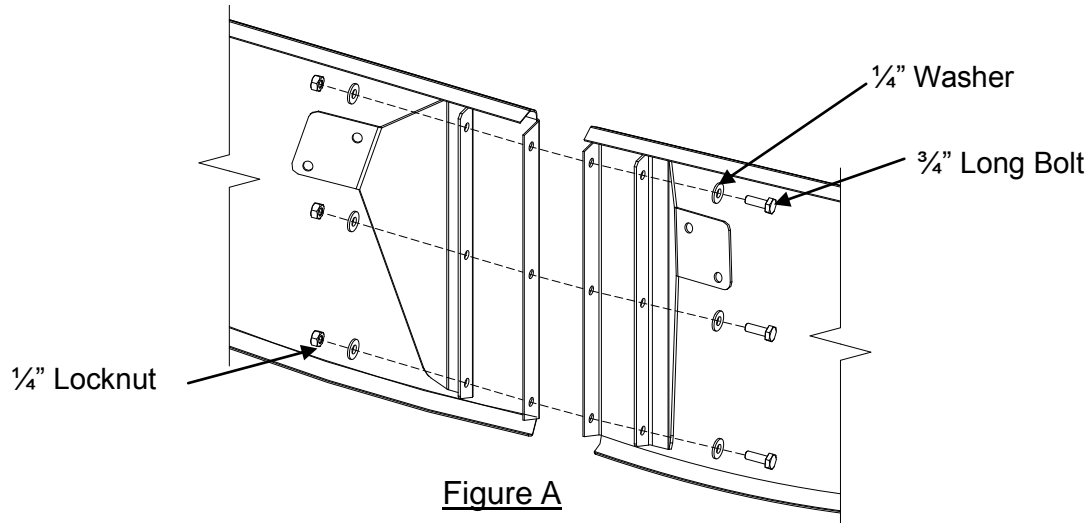

Figure A

6. Fasten remaining 2 brackets to the cab as shown in Figure B. Do not tighten fully. Use silicone in holes of cab to create a watertight seal. Peel approximately one inch of tape from brackets.

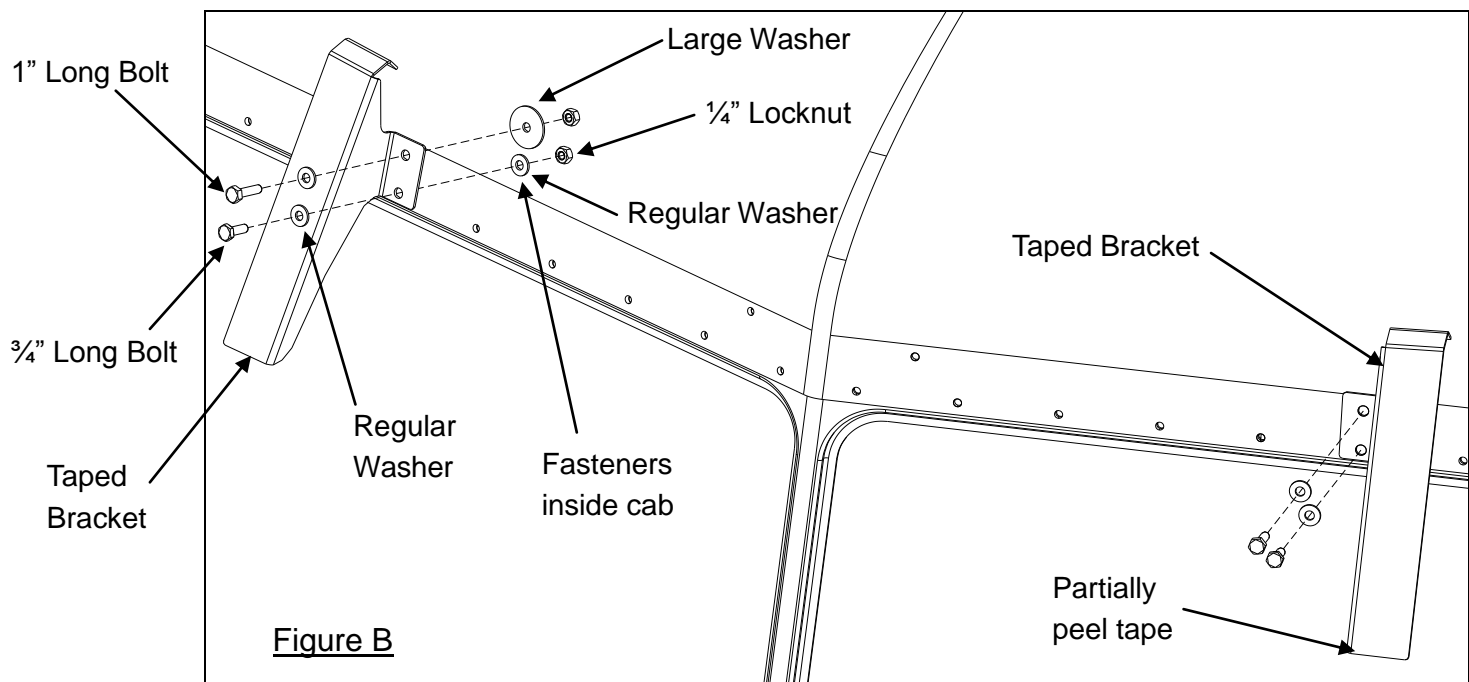
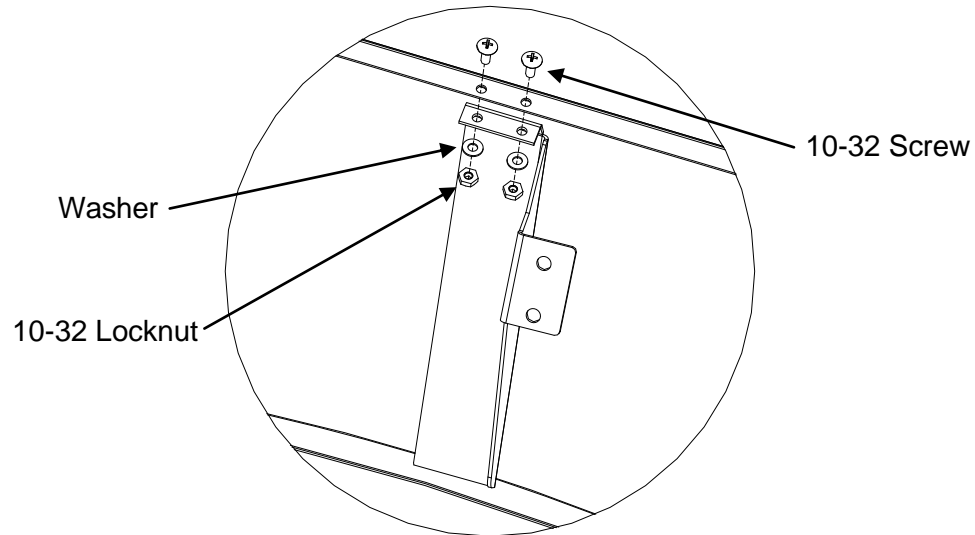

Figure B

7. Fasten center bracket/sunvisor assembly to the cab with fasteners oriented in the same manner as shown in Figure B. Do not tighten fully. Use silicone in holes of cab to create a watertight seal.
8. Fasten taped brackets to visor halves as shown in Figure C



9. Fasten the ends of the sunvisor into the side of the cab with the fasteners set aside in step 1. Do not tighten fully allowing for adjustment.
10. Remove remaining 2 sided tape from brackets and clamp taped surface of brackets to visor. To ensure proper adhesion allow for enough curing time.
11. Fully fasten brackets to the cab and visor ends into side of cab.