

## INTAKE ACCENT LIGHT & HARNESS Kenworth W990

READ ALL INSTRUCTIONS BEFORE PROCEEDING

### INSTALLATION INSTRUCTIONS:

1. With the hood in the open position, remove the left headlamp cover and both fender-liners (below)

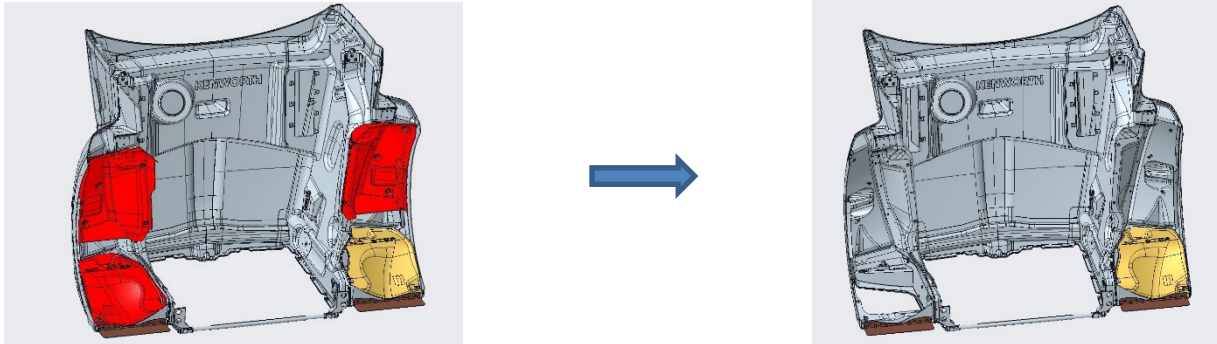

2. Gently loosen the nuts holding the left side turn indicator (be sure not to accidentally drop the nuts inside the hood skin itself), remove the side turn indicator, and disconnect the side turn indicator from the hood harness.

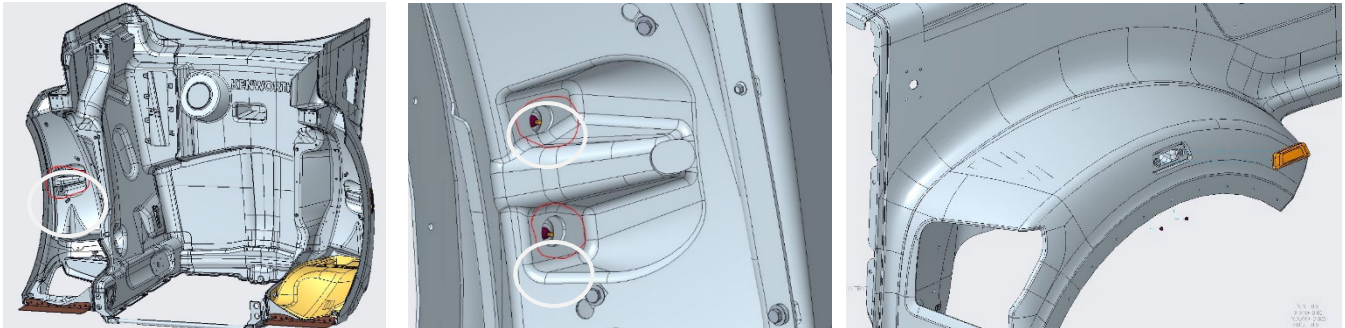

3. Connect the supplied wire harness to the left turn indicator hood harness by threading through the "tunnel" in the hood skin.

Large connectors  
(x2)

- Pass through "tunnel"
- Connect to left turn indicator

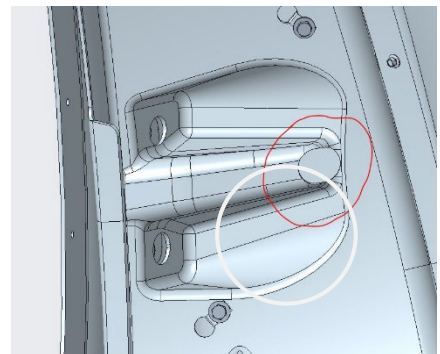
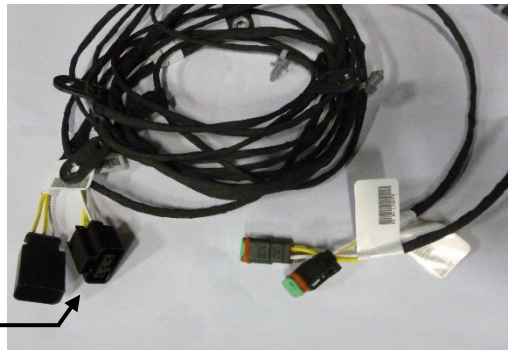

4. Reinstall the left side turn indicator (do not overtighten the nuts onto the studs).

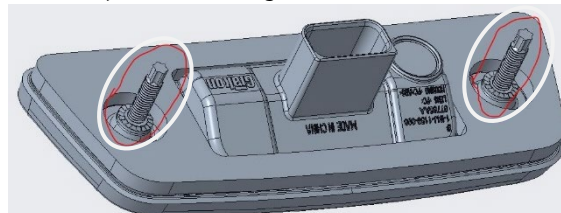

5. Route the Wire Harness down the length of the existing hood-harness, zip-tying as you go (left below). Stop when you reach the left side hood hinge (right below).



6. Re-install the left headlamp cover

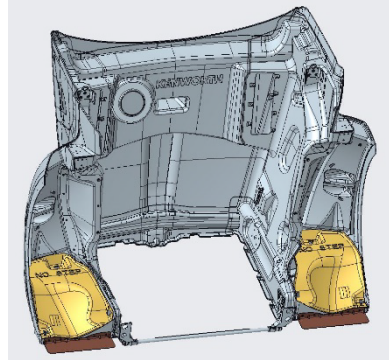
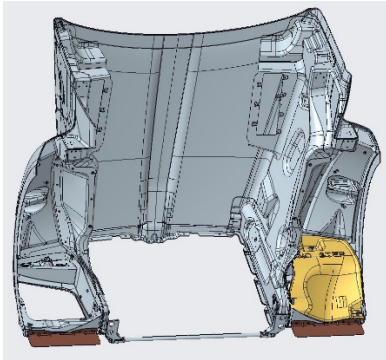

7. Route the longer branch of the supplied Harness across the width of the grille, zip-tying to the existing hood harness as you go.



The following steps (Step 8 through Step 13) apply to both the left & right sides.

8. Insert wire-harness's "fir-tree" clips into the hole shown below.

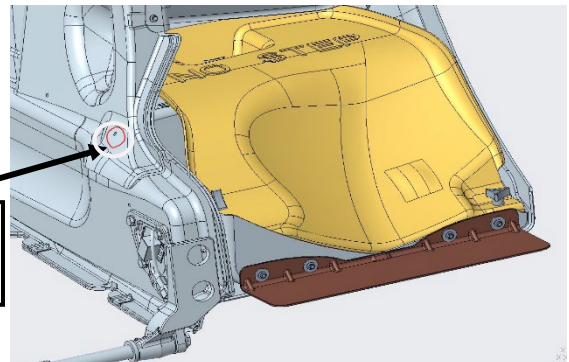
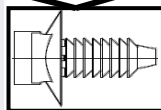
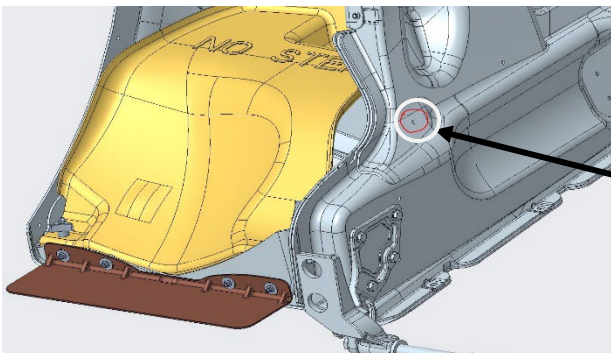

9. Attached the wire-harness's bolt-through zip-ties with the circled screws (use existing fasteners).

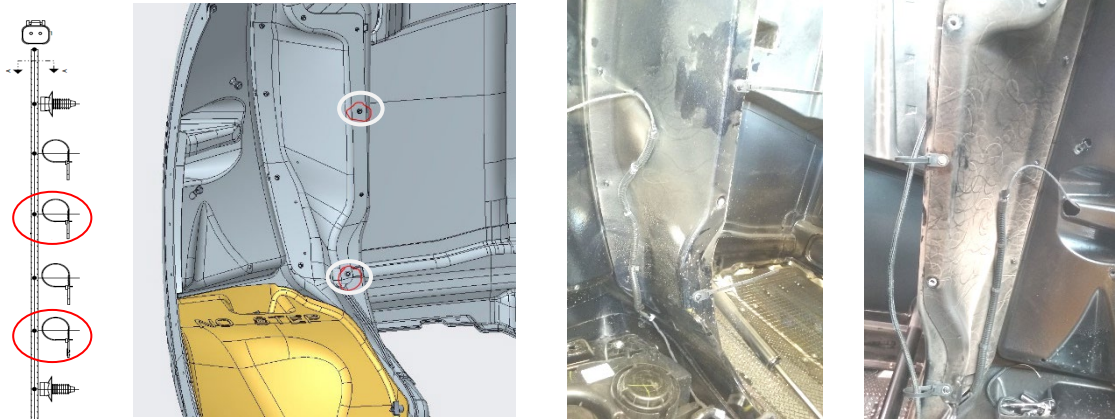

10. Reinstall the fender-liners, wedge the circled bolt-through zip-ties between fender-liner & hood skin before bolting down (use existing fasteners).

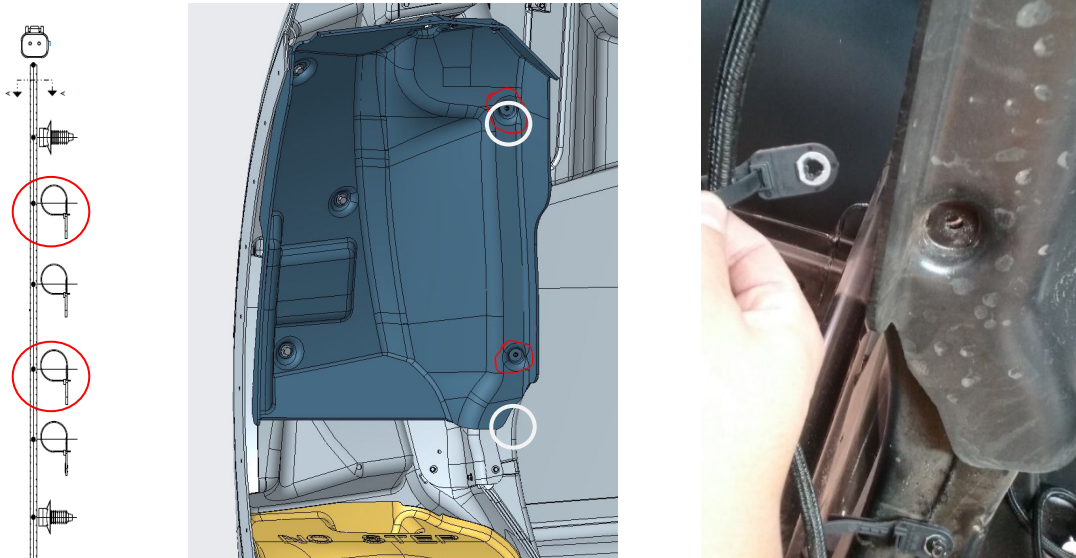

11. Drill a 1/4" hole in the location shown below to route the final "fir-tree" clips.

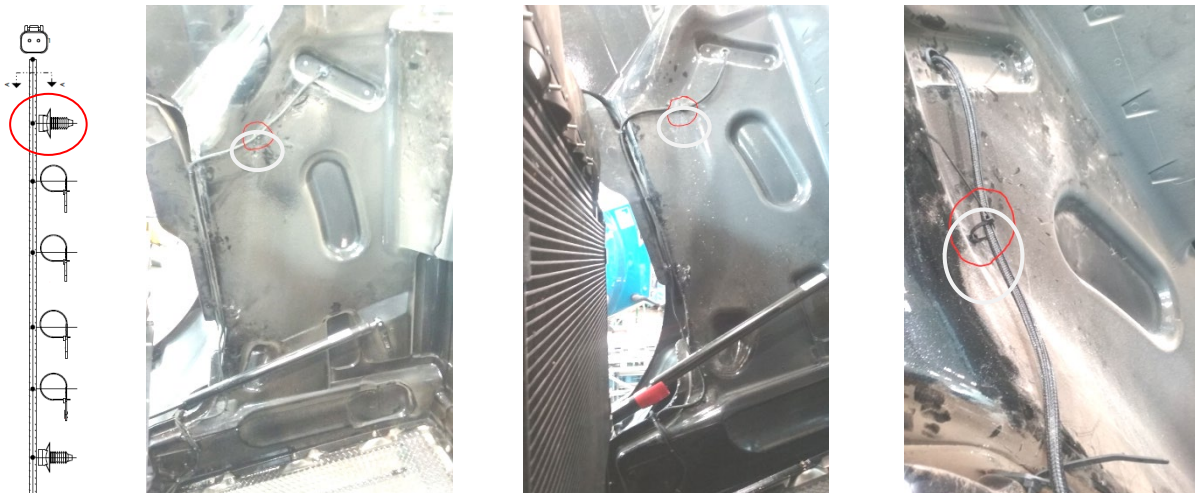

12. Drill a 7/8" hole through the hood (in the location circled below), add grommet, and thread the harness through.

**Tip: Hold the intake-frame in place to mark grommet-hole location on the outside of hood.**



13. Remove the air intakes carefully, disassemble them, clean mounting surface with alcohol, tape down the Intake Accent Light as shown, reassemble the intake, and reinstall on the truck. Connect harness.



Intake Accent Light strip install

## GARNITURE LUMINEUSE D'ENTRÉE D'AIR ET FAISCEAU Kenworth W990

LIRE TOUTES LES INSTRUCTIONS AVANT DE COMMENCER.

### INSTRUCTIONS D'INSTALLATION:

1. Avec le capot en position ouverte, retirez le couvercle du phare de gauche et les deux fausses ailes (ci-dessous)

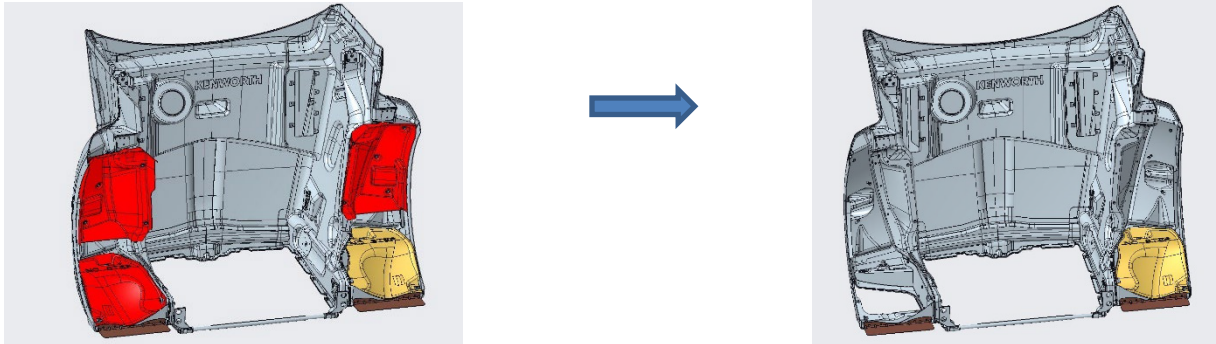

2. Desserrez délicatement les écrous qui maintiennent le clignotant côté gauche (veillez à ne pas accidentellement laisser tomber les écrous à l'intérieur de la coque du capot), retirez le clignotant et de déconnectez le clignotant du faisceau du capot

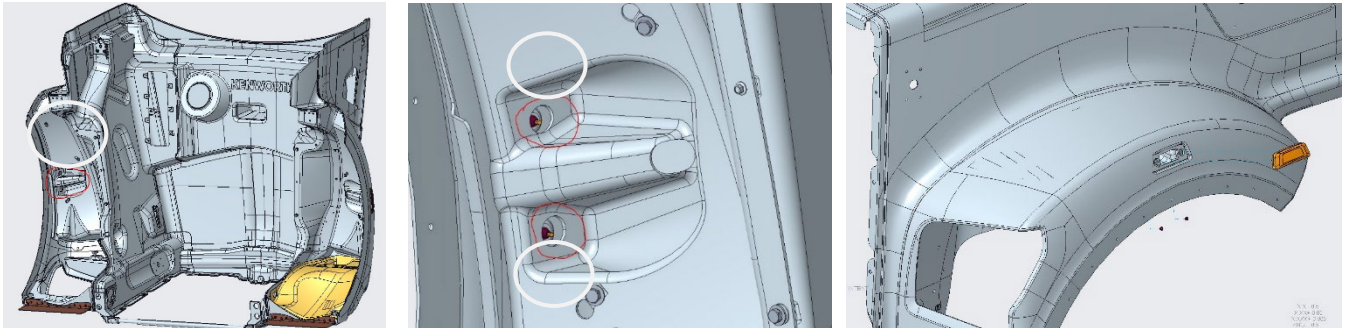

3. Connectez le faisceau de câbles fourni au faisceau du capot du clignotant de gauche en le passant par le canal dans la coque du capot.

Gros connecteurs (x2)

- Passez à travers du canal
- Connectez au clignotant de gauche

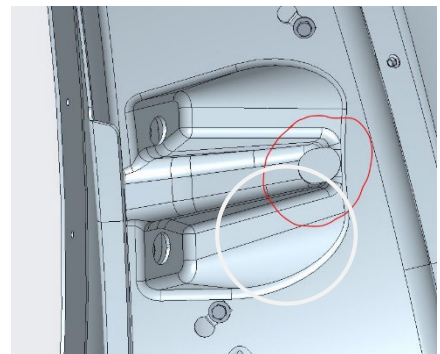
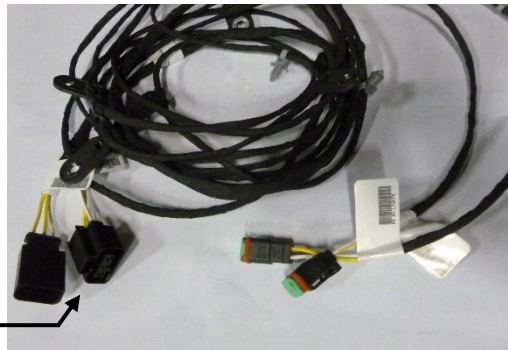

4. Réinstallez le clignotant côté gauche (ne pas trop serrer les écrous sur les goujons)

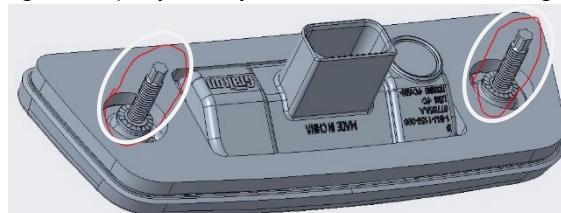

5. Faites passer le faisceau de fils le long du faisceau existant, en le fixant au fur et à mesure (voir ci-dessous à gauche). Arrêtez lorsque vous avez atteint la charnière gauche du capot (voir ci-dessous à droite).



6. Réinstaller le couvercle du phare gauche.

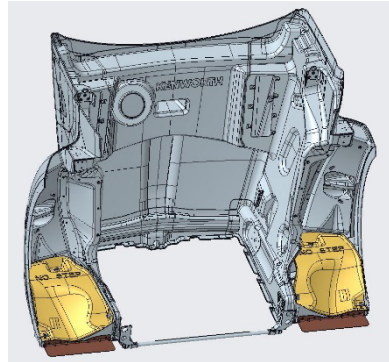
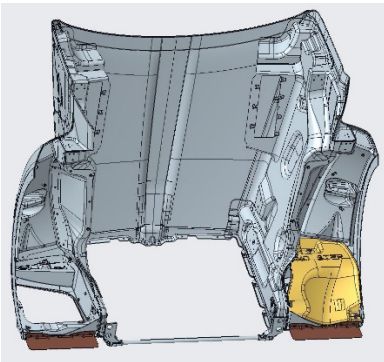

7. Faites passer la branche longue du faisceau fourni sur toute la largeur de la calandre, en le fixant au dur et à mesure sur le faisceau du capot existant.



Les étapes suivantes (étape 8 à étape 13) s'appliquent à la fois aux côtés gauche et droit.

8. Insérez les clips de faisceau type sapin dans le trou indiqué ci-dessous.

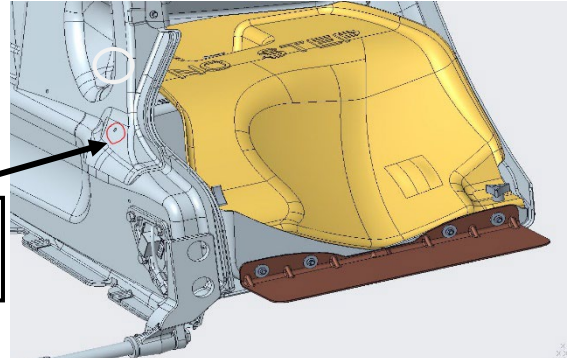
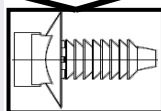
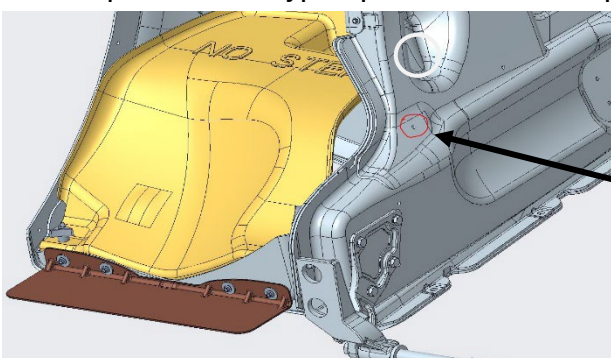

9. Fixez le faisceau électrique au moyen des colliers de serrage avec les vis encrêlées (utilisez les fixations existantes)

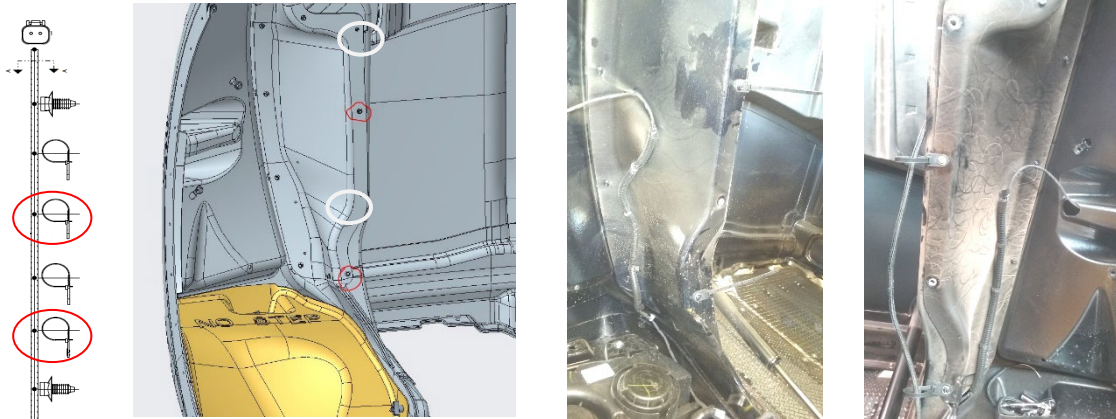

10. Réinstallez les fausses ailes, caliez les colliers de serrage encrêlés entre la fausse aile et la coque du capot avant de boulonner (utilisez les fixations existantes).

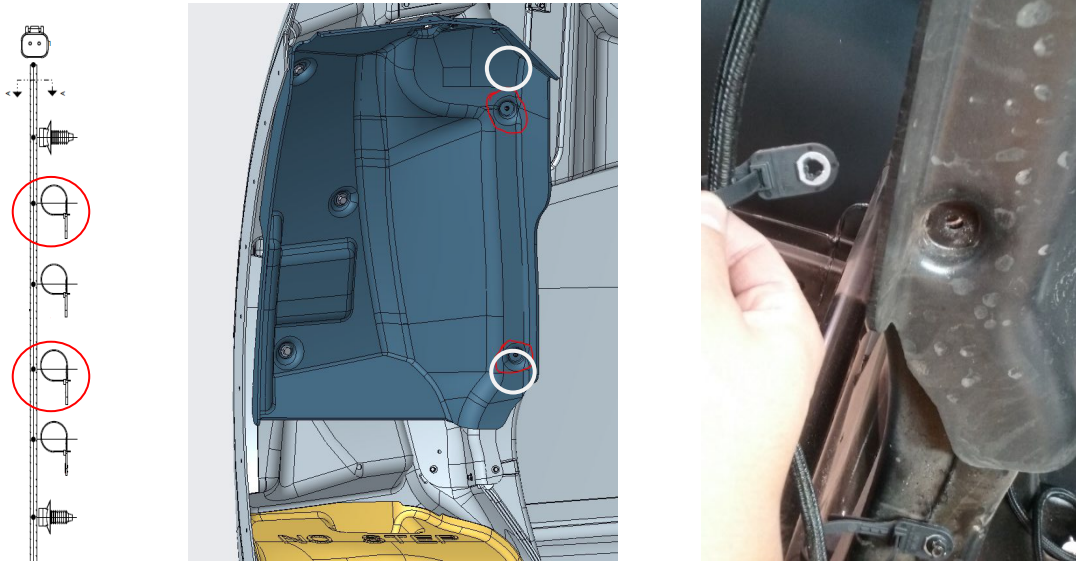

11. Percez un trou de 1/4" à l'endroit indiqué ci-dessous pour passer les derniers clips type "sapin" (utilisez les fixations existantes)



12. Percer un trou de 7/8" à travers le capot (à l'endroit encadré ci-dessous), ajoutez passe-câble, et passez le faisceau par le trou.

**Conseil :** Maintenez le cadre de l'entrée d'air en place pour marquer l'emplacement du trou passe-fil à l'extérieur du capot.



13. Retirez soigneusement les entrées d'air, démontez-les, nettoyez la surface d'installation de l'alcool, collez la garniture lumineuse d'entrée d'air tel qu'indiqué, ré-assemblez l'entrée d'air, et remplacez-la sur le camion. Brancher le faisceau de câble.



Emplacement d'installation de la garniture



## LUZ DE ACENTO DE ADMISIÓN & ARNÉS Kenworth W990

LEA TODAS LAS INSTRUCCIONES ANTES DE PROCEDER.

### INSTRUCCIONES DE INSTALACIÓN:

1. Con el capó en posición abierta, quite la cubierta del faro izquierdo y ambos revestimientos de defensa (abajo)



2. Suavemente afloje los tornillos sujetando la intermitente izquierda (asegúrese de no botar los tornillos adentro de la cara del capó misma), quite la luz intermitente y desconéctelas del arnés del capó

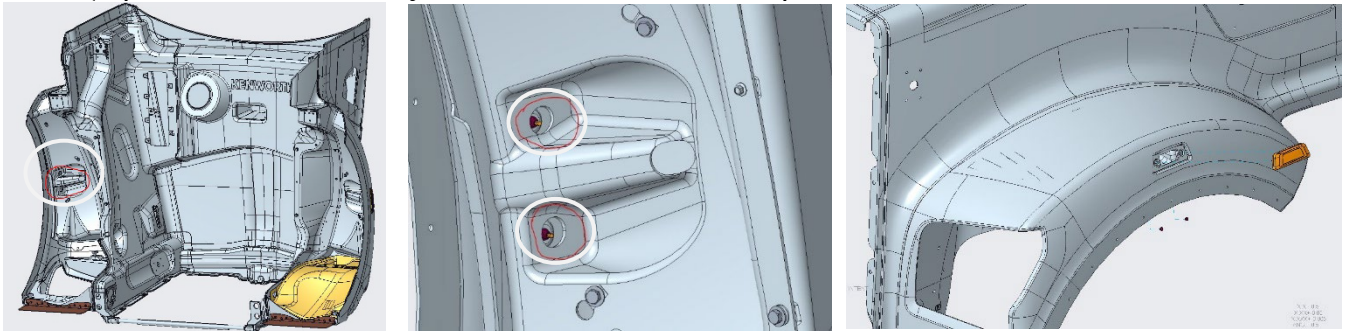

3. Conecte el arnés de cable provisto al arnés cobertor de la intermitente izquierda pasándola por el "tunnel" en la cara del capó.

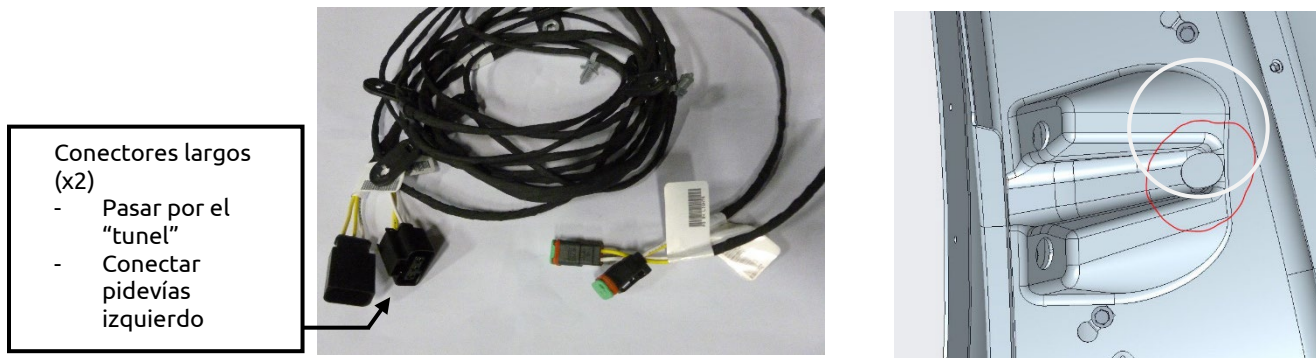

4. Instale de nuevo las intermitentes izquierdas (no apriete demasiado las tuercas en los tornillos)

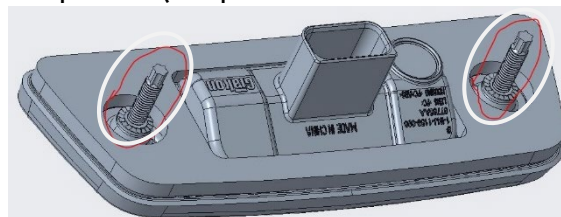

5. Enrute el arnés de cables a lo largo del arnés del capó existente, atando la cremallera sobre la marcha (izquierda abajo). Pare cuando llegue a la bisagra del capo del lado izquierdo (derecha abajo).



6. Instale de nuevo la cubierta del faro izquierdo.

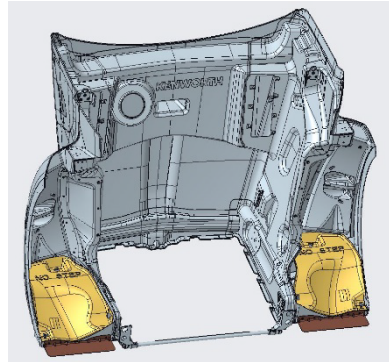
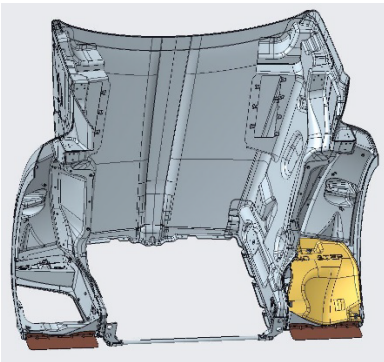

7. Pase la rama más larga del arnés provisto a lo ancho de la rejilla, atando la cremallera al arnés de la capucha existente sobre la marcha.



Los siguientes pasos (Paso 8 al paso 13) aplica a lado derecho e izquierdo.

8. Inserte los clips del arnés de alambres "fir-tree" en el agujero indicado abajo.

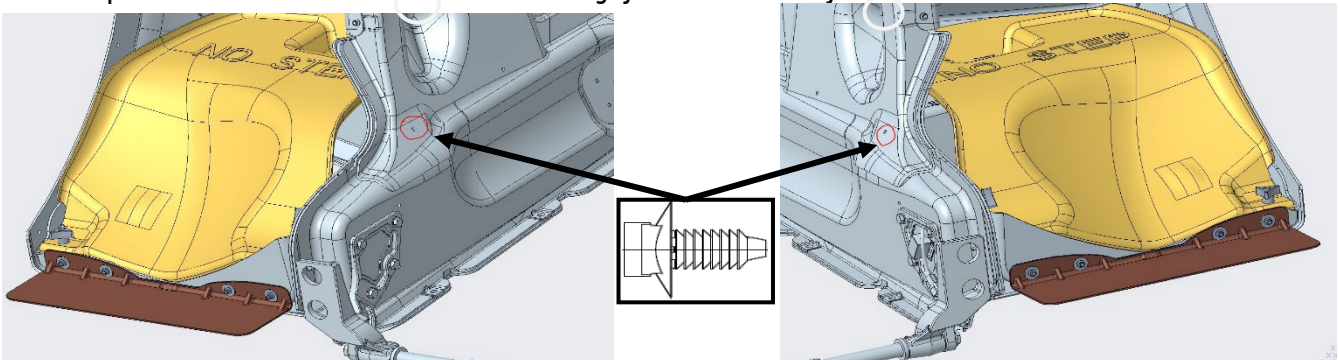

9. Sujete las bridas con pernos del arnés de cables con los tornillos encerrados en un círculo (use los sujetadores existentes).

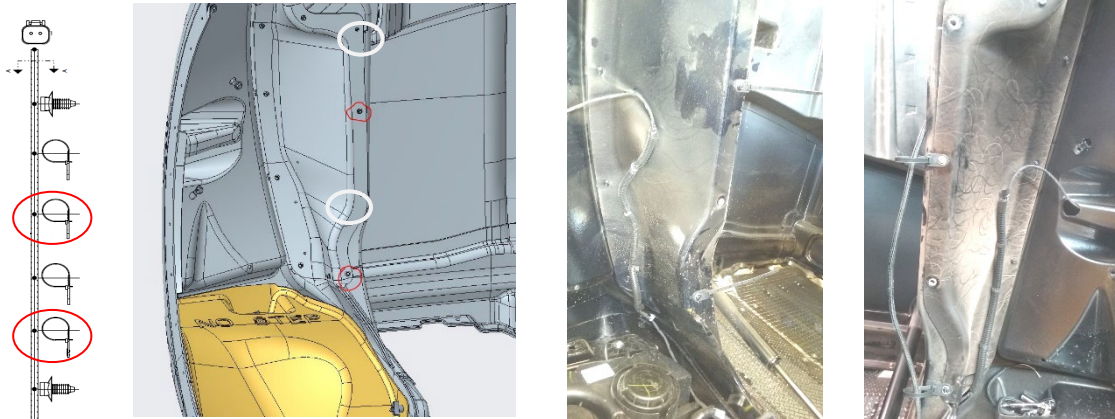

10. Coloque las cubiertas de la defensa, Coloque las bridas circulares con pernos entre el forro de la defensa y la cara del capó antes de atornillar (use los sujetadores existentes).

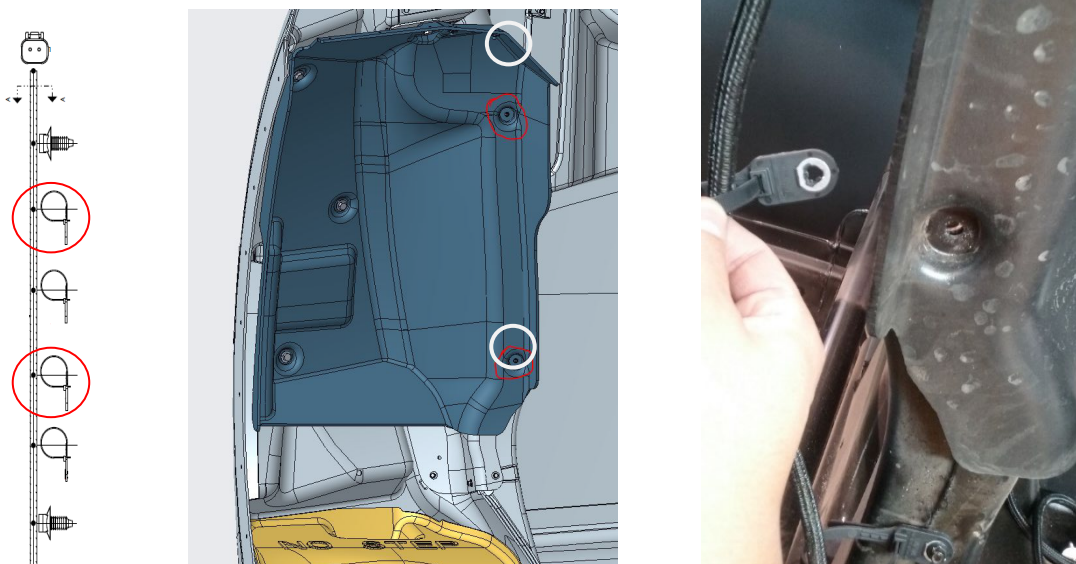

11. Perfore una agujero de 1/4" en la localización mostrada abajo, para dirigir los clips "fir-tree" finales.

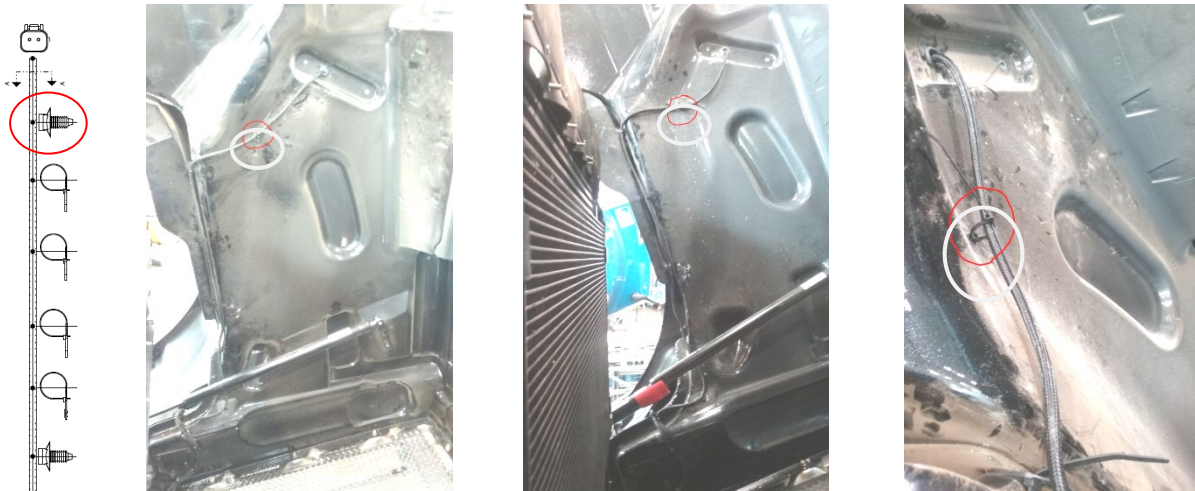

12. Perfore una agujero de 7/8" por el capó (en la localización circulada abajo), ponga un ojal, y meta el arnés a través.

**CONSEJO:** sostenga el marco de admisión para marcar el agujero/ojal por afuera del capó.

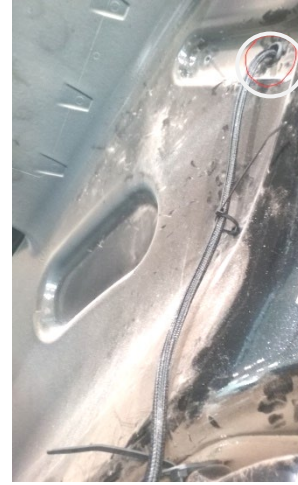

13. Quite las admisiones de aire con cuidado, desensamblelas, limpie la superficie con alcohol wipes, adhiera las las luces de acento como se muestra, ensamble de nuevo la admisión y reinstale en el camión. Conecte el arnés.



Localización de instalación de luz de acento de admisiónlocation