

# LICENSE PLATE HOLDER, SINGLE

## 5700XE, WESTERN STAR

Panelite, Inc. · 275 Industrial Road · Cambridge, ON N3H 4R7 · Phone: 519-884-8555 · Toll Free: 1-877-884-8555 · FAX 519-884-8553 · website: www.panelite.com

### Installation Procedure :

1. Remove the license plate bezel.
2. Remove the plastic coating from the plate holder except on the front face.
3. Fasten the brackets to the plate holder as shown in diagram below. Do not tighten fully in order to allow rotation of brackets.
4. Loosen 2 bolts which are underneath the bumper. Bolts are about 11" apart.

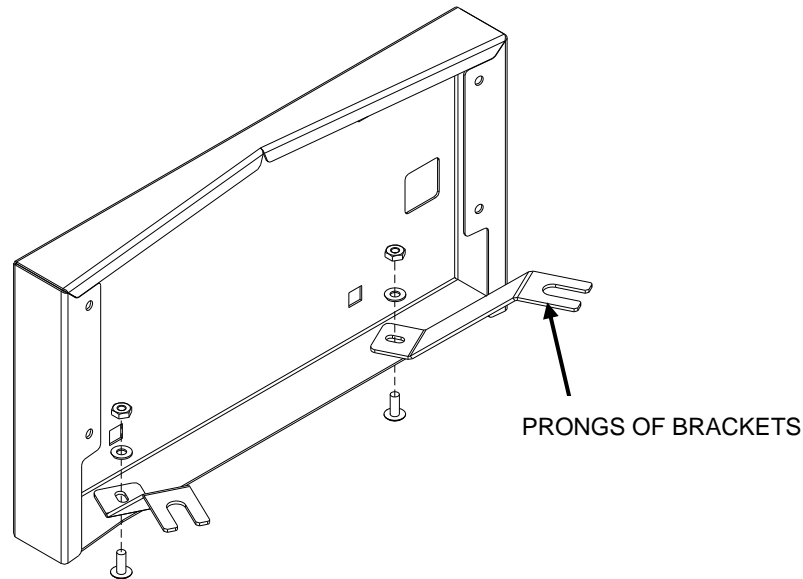

5. Align the plate holder onto the bumper by ensuring the prongs of the brackets slide onto the bolts loosened from step 3 and center the plate holder horizontally.
6. With the plate holder aligned, carefully mark through 4 holes onto the bumper.

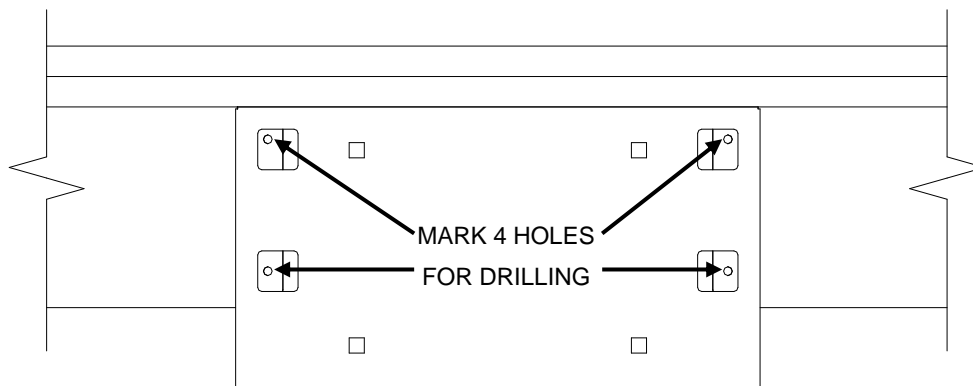

7. Remove the plate holder and drill through 4 marked holes with  $\text{Ø}1/8$ " drill bit.
8. Install plate holder by first fastening brackets, then screwing into drilled holes.
9. Remove remaining plastic, attach bezel and insert license plate.